

HALOGEN PROJECTOR – 150W/500W

CE	IP55			230V 50Hz	Class 1
----	------	--	--	--------------	---------

Body: Aluminium die-cast casing
Painting: Black & White
Reflector: Anode process polished aluminium
Diffuser: Heat resistant and shock-proof protective glass
Supporting brace: Painted steel bar
Equipment: Silicone rubber sealing. Porcelain lampholder. Polyamide wiring box. Cableglend. Terminal blocks. **Lamp included.**
Spare-parts: Glass for projector 150/500/1000/1500. Please consult for other spare parts & accessories.



REF.	POWER	CONNECTION	COLOUR
61182EC	150W	R7s	Black
61183EC	150W	R7s	White

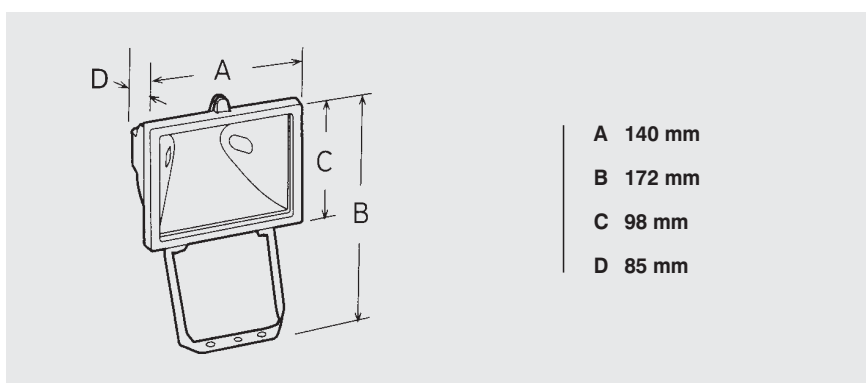

REF.	POWER	CONNECTION	COLOUR
61181EC	500W	R7s	Black
61180EC	500W	R7s	White

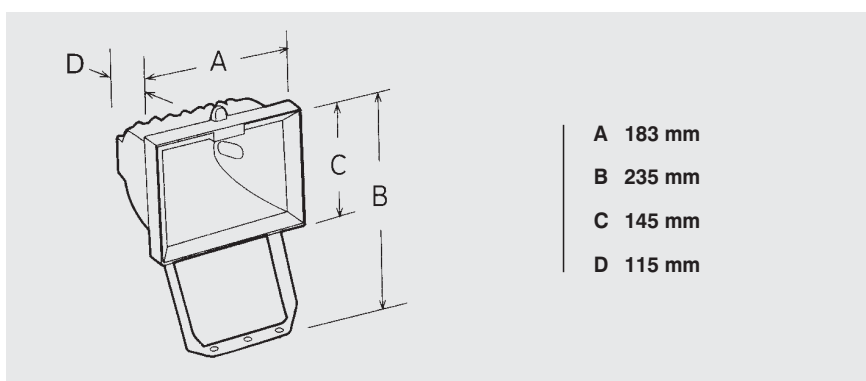

HALOGEN PROJECTOR – 500W/1500W



REF.	POWER	CONNECTION	COLOUR
61146EC	500W	R7s	Black

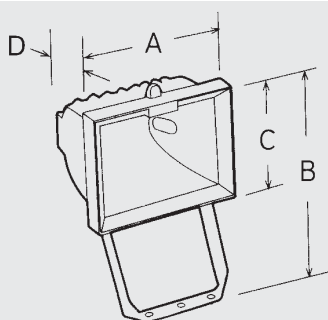

- A 184 mm
- B 265 mm
- C 148 mm
- D 115 mm



REF.	POWER	CONNECTION	COLOUR
61124EC	1000W	R7s	Black

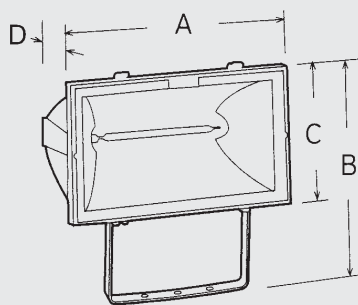

- A 273 mm
- B 285 mm
- C 202 mm
- D 135 mm



REF.	POWER	CONNECTION	COLOUR
61101EC	1500W	R7s	Black

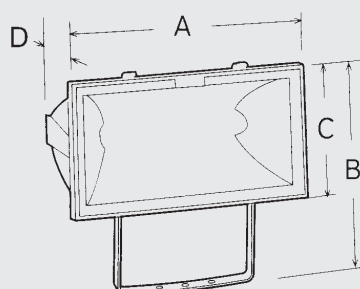

- A 345 mm
- B 366 mm
- C 226 mm
- D 170 mm



HALOGEN PROJECTOR - GOBELUX/1000W

CE IP65 230V Class 1

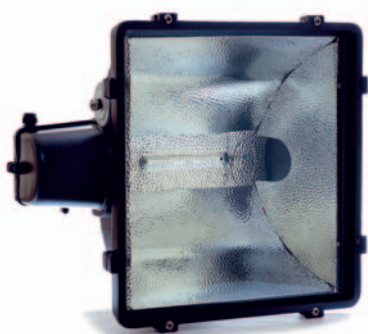

Body: Aluminium die-cast casing
Painting: Black
Reflector: Anode process polished aluminium
Diffuser: Heat resistant and shock-proof protective glass
Supporting brace: Painted steel bar
Equipment: Silicone rubber sealing. Porcelain lampholder. Polyamide wiring box. Cable gland. Terminal blocks. Zinc plated internal screws. Stainless steel external screws.

Spare-parts: Glass for projector GOBELUX/1000W. Please consult for other spare parts, accessories & colours

REF.	POWER	CONNECTION	COLOUR
68300	1000W	E-40	Black
68300.1	HM-1000W	E-40	Black
68300.10	HM-1000W c/lamp.	E-40	Black
68300.2	VSAP-1000W	E-40	Black
68300.20	VSAP-1000W c/lamp.	E-40	Black

Wiring box located maximum 25 meters from projector.

HM 1000W

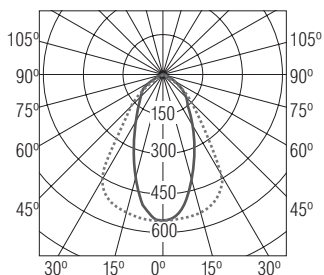

VSAP 1000W

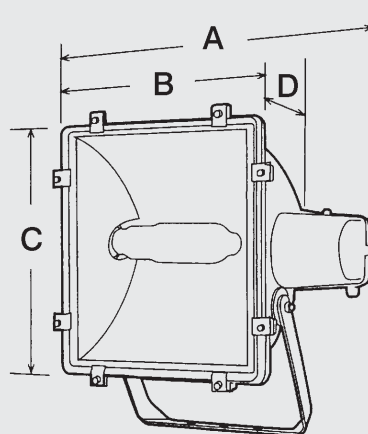
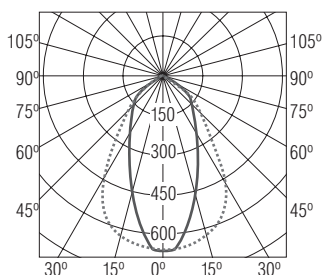

- A 560 mm
- B 465 mm
- C 500 mm
- D 290 mm

HALOGEN PROJECTOR – FARELUX/70-150W

CE	IP65		230V	Class 1
----	------	--	------	---------

Body	Aluminium die-cast casing
Painting	Black/Grey
Reflector	Anode process polished aluminium. Available symmetrical, Asymmetrical (A) and Professional.
Diffuser	Heat resistant and shock-proof protective glass
Supporting brace	Painted steel bar
Equipment	Silicone rubber sealing. Porcelain lampholder. Polyamide wiring box. Cablegland. Terminal blocks. Zinc plated internal screws. Stainless steel external screws.
Spare-parts	Glass for projector FARELUX/70-150W. Please consult for other spare parts, accessories & colours

REF.	POWER	CONNECTION	COLOUR
68110/68111	70W	RX7s	Black/Grey
68110A/68111A	70W	RX7s	Black/Grey
68110.1/68111.1	HM-70W	RX7s	Black/Grey
68110.1A/68111.1A	HM-70W	RX7s	Black/Grey
68110.10/68111.10	HM-70W c/lamp.	RX7s	Black/Grey
68110.10A/68111.10A	HM-70W c/lamp.	RX7s	Black/Grey
68110.2/68111.2	VSAP-70W	RX7s	Black/Grey
68110.2A/68111.2A	VSAP-70W	RX7s	Black/Grey
68120/68122	150W	RX7s	Black/Grey
68120A/68122A	150W	RX7s	Black/Grey
68120.1/68122.1	HM-150W	RX7s	Black/Grey
68120.1A/68122.1A	HM-150W	RX7s	Black/Grey
68120.10/68122.10	HM-150W c/lamp.	RX7s	Black/Grey
68120.10A/68122.10A	HM-150W c/lamp.	RX7s	Black/Grey
68120.2/68122.2	VSAP-150W	RX7s	Black/Grey
68120.2A/68122.2A	VSAP-150W	RX7s	Black/Grey
68123-Professional	150W	RX7s	Black
68123.1-Professional	HM-150W	RX7s	Black
68123.10-Professional	HM-150W c/lamp.	RX7s	Black

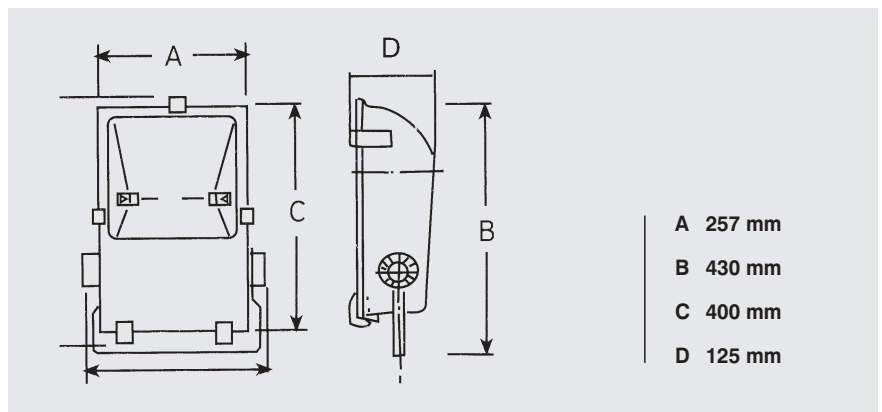
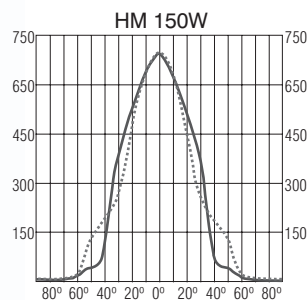

PROJECTOR - FARELUX/250-400W

CE	IP65		230V	Class 1
----	------	--	------	---------

Body	Aluminium die-cast casing
Painting	Black/Grey
Reflector	Anode process polished aluminium. Available symmetrical and Asymmetrical (A).
Diffuser	Heat resistant and shock-proof protective glass
Supporting brace	Painted steel bar
Equipment	Silicone rubber sealing. Porcelain lampholder. Polyamide wiring box. Cable gland. Terminal blocks. Zinc plated internal screws. Stainless steel external screws.
Spare-parts	Glass for projector FARELUX/250-400W. Please consult for other spare parts, accessories & colours.

REF.	POWER	CONNECTION	COLOUR
68130/68132	250/400W	E40	Black/Grey
68130A/68132A	250/400W	E40	Black/Grey
68130.1/68132.1	HM-250W	E40	Black/Grey
68130.10/68132.10	HM-250W c/lamp.	E40	Black/Grey
68130.1A/68132.1A	HM-250W	E40	Black/Grey
68130.10A/68132.10A	HM-250W c/lamp.	E40	Black/Grey
68130.2/68132.2	HM-400W	E40	Black/Grey
68130.20/68132.20	HM-400W c/lamp.	E40	Black/Grey
68130.2A/68132.2A	HM-400W	E40	Black/Grey
68130.20A/68132.20A	HM-400W c/lamp.	E40	Black/Grey
68130.3/68132.3	VSAP-250W	E40	Black/Grey
68130.30/68132.30	VSAP-250W c/lamp.	E40	Black/Grey
68130.3A/68132.3A	VSAP-250W	E40	Black/Grey
68130.30A/68132.30A	VSAP-250W c/lamp.	E40	Black/Grey
68130.4/68132.4	VSAP-400W	E40	Black/Grey
68130.40/68132.40	VSAP-400W c/lamp.	E40	Black/Grey
68130.4A/68132.4A	VSAP-400W	E40	Black/Grey
68130.40A/68132.40A	VSAP-400W c/lamp.	E40	Black/Grey
68130.5/68132.5	VM-250W	E40	Black/Grey
68130.50/68132.50	VM-250W c/lamp.	E40	Black/Grey
68130.5A/68132.5A	VM-250W	E40	Black/Grey
68130.50A/68132.50A	VM-250W c/lamp.	E40	Black/Grey

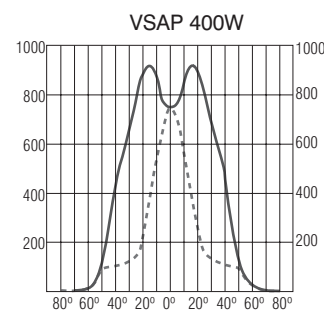
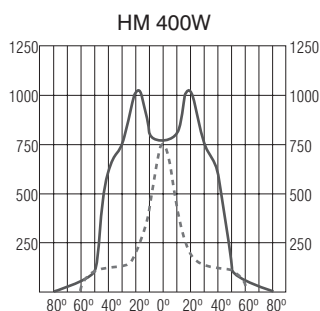

PROJECTOR - FARELUX/250-400W

CE	IP65	⚡	230V	Class 1
----	------	---	------	---------

Body	Aluminium die-cast casing
Painting	Black
Reflector	Anode process polished aluminium. Available narrow beam and professional.
Diffuser	Heat resistant and shock-proof protective glass
Supporting brace	Painted steel bar
Equipment	Silicone rubber sealing. Porcelain lampholder. Polyamide wiring box. Cable gland. Terminal blocks. Zinc plated internal screws. Stainless steel external screws.
Spare-parts	Glass for projector FARELUX/250-400W. Please consult for other spare parts, accessories & colours.

REF.	POWER	CONNECTION	COLOUR
68134-Intensivo	250/400W	E40	Black
68134.1-Intensivo	HM-250W	E40	Black
68134.10-Intensivo	HM-250W c/lamp.	E40	Black
68134.2-Intensivo	HM-400W	E40	Black
68134.20-Intensivo	HM-400W c/lamp.	E40	Black
68134.3-Intensivo	VSAP-250W	E40	Black
68134.30-Intensivo	VSAP-250W c/lamp.	E40	Black
68134.4-Intensivo	VSAP-400W	E40	Black
68134.40-Intensivo	VSAP-400W c/lamp.	E40	Black
68133-Profesional	250/400W	Fc2	Black
68133.1-Profesional	HM-250W	Fc2	Black
68133.10-Profesional	HM-250W c/lamp.	Fc2	Black
68133.2-Profesional	HM-400W	Fc2	Black

