

INDUSTRIAL LIGHTING – PANALUX/150-250-400W

CE	IP23	230V	Class 1
----	------	------	---------

IP55	Only reflector with glass
------	---------------------------

Body Aluminium die-cast casing
Wiring box Aluminium powders painted.
Reflector Anode process polished aluminium. Smooth.
Diffuser Heat resistant and UV resistant glass.
Equipment Rubber sealing. Porcelain lampholder. Accessories plate easily removable for maintenance. Cable gland. Terminal blocks. Zinc plated internal screws. Stainless steel external screws. Painted hanger and safety chain.

Spare-parts Please consult for spare parts & accessories.



REF.	POWER	CONNECTION
68140	150/250/400W	E40
68140.1	HM-150W	E27
68140.10	HM-150W c/lamp.	E27
68140.2	HM-250W	E40
68140.20	HM-250W c/lamp.	E40
68140.3	HM-400W	E40
68140.30	HM-400W c/lamp.	E40
68140.4	VSAP-150W	E40
68140.40	VSAP-150W c/lamp.	E40
68140.5	VSAP-250W	E40
68140.50	VSAP-250W c/lamp.	E40
68140.6	VSAP-400W	E40
68140.60	VSAP-400W c/lamp.	E40
68140.7	VM-250W	E40
68140.70	VM-250W c/lamp.	E40
68140.8	VM-400W	E40
68140.80	VM-400W c/lamp.	E40
68990	Glass closing & safety chain D-480mm	

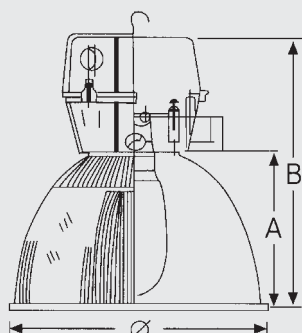
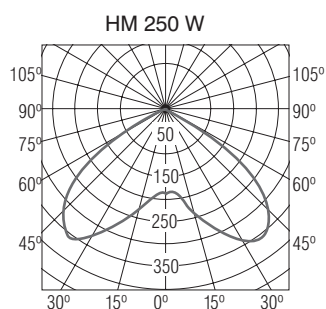

Ø 480 mm
 A 300 mm
 B 570 mm

INDUSTRIAL LIGHTING – VENULUX/150-250-400W

CE	IP23	230V	Class 1
----	------	------	---------

IP55	Only reflector with glass
------	---------------------------

Body	Aluminium die-cast casing
Wiring box	Aluminium powders painted.
Reflector	Anode process polished aluminium. Faceted
Diffuser	Heat resistant and UV resistant glass.
Equipment	Rubber sealing. Porcelain lampholder. Accessories plate easily removable for maintenance. Cablegland . Terminal blocks. Zinc plated internal screws. Stainless steel external screws. Painted hanger and safety chain.

Spare-parts Please consult for spare parts & accessories.



REF.	POWER	CONNECTION
68150	150/250/400W	E40
68150.1	HM-150W	E27
68150.10	HM-150W c/lamp.	E27
68150.2	HM-250W	E40
68150.20	HM-250W c/lamp.	E40
68150.3	HM-400W	E40
68150.30	HM-400W c/lamp.	E40
68150.4	VSAP-150W	E40
68150.40	VSAP-150W c/lamp.	E40
68150.5	VSAP-250W	E40
68150.50	VSAP-250W c/lamp.	E40
68150.6	VSAP-400W	E40
68150.60	VSAP-400W c/lamp.	E40
68150.7	VM-250W	E40
68150.70	VM-250W c/lamp.	E40
68150.8	VM-400W	E40
68150.80	VM-400W c/lamp.	E40
68990	Glass closing & safety chain D-480mm	

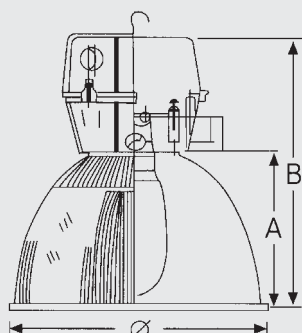
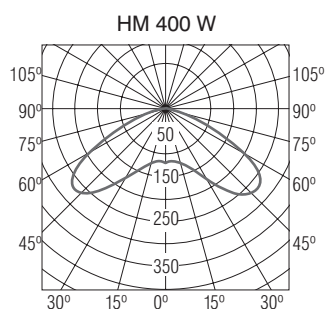

Ø 480 mm
A 300 mm
B 511 mm