

HALOGEN PROJECTOR – 150W/500W

| | | | | | |
|----|------|--|--|--------------|---------|
| CE | IP55 | | | 230V 50Hz | Class 1 |
|----|------|--|--|--------------|---------|

Body: Aluminium die-cast casing
Painting: Black & White
Reflector: Anode process polished aluminium
Diffuser: Heat resistant and shock-proof protective glass
Supporting brace: Painted steel bar
Equipment: Silicone rubber sealing. Porcelain lampholder. Polyamide wiring box. Cablegland. Terminal blocks. **Lamp included.**
Spare-parts: Glass for projector 150/500/1000/1500. Please consult for other spare parts & accessories.



| REF. | POWER | CONNECTION | COLOUR |
|---------|-------|------------|--------|
| 61182EC | 150W | R7s | Black |
| 61183EC | 150W | R7s | White |

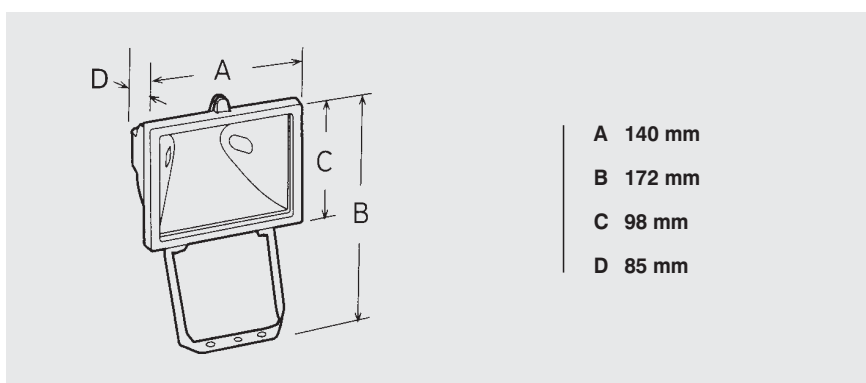

| REF. | POWER | CONNECTION | COLOUR |
|---------|-------|------------|--------|
| 61181EC | 500W | R7s | Black |
| 61180EC | 500W | R7s | White |

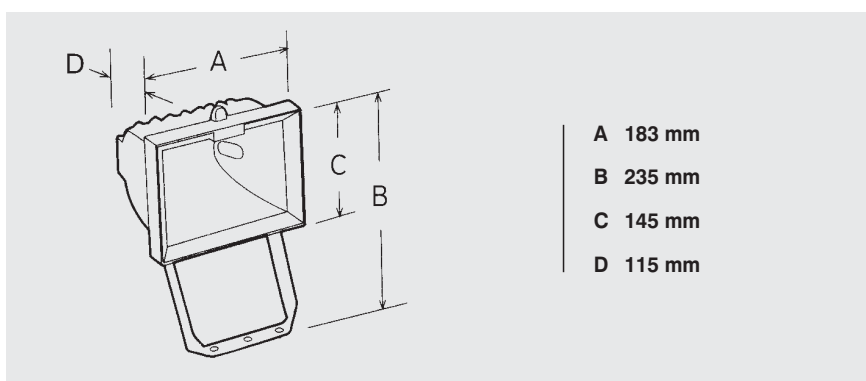

HALOGEN PROJECTOR – 500W/1500W



| REF. | POWER | CONNECTION | COLOUR |
|---------|-------|------------|--------|
| 61146EC | 500W | R7s | Black |

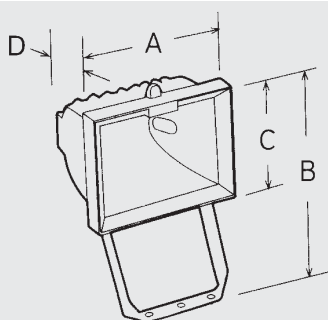

- A 184 mm
- B 265 mm
- C 148 mm
- D 115 mm



| REF. | POWER | CONNECTION | COLOUR |
|---------|-------|------------|--------|
| 61124EC | 1000W | R7s | Black |

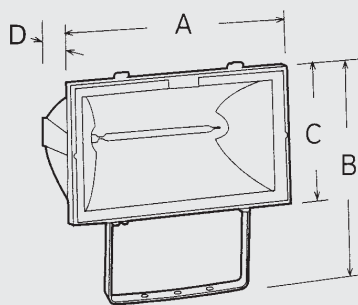

- A 273 mm
- B 285 mm
- C 202 mm
- D 135 mm



| REF. | POWER | CONNECTION | COLOUR |
|---------|-------|------------|--------|
| 61101EC | 1500W | R7s | Black |

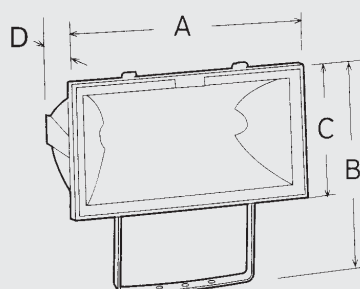

- A 345 mm
- B 366 mm
- C 226 mm
- D 170 mm



HALOGEN PROJECTOR - GOBELUX/1000W

CE IP65 230V Class 1

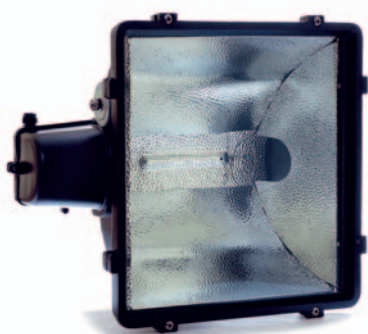

Body: Aluminium die-cast casing
Painting: Black
Reflector: Anode process polished aluminium
Diffuser: Heat resistant and shock-proof protective glass
Supporting brace: Painted steel bar
Equipment: Silicone rubber sealing. Porcelain lampholder. Polyamide wiring box. Cableglend. Terminal blocks. Zinc plated internal screws. Stainless steel external screws.

Spare-parts: Glass for projector GOBELUX/1000W. Please consult for other spare parts, accessories & colours

| REF. | POWER | CONNECTION | COLOUR |
|----------|--------------------|------------|--------|
| 68300 | 1000W | E-40 | Black |
| 68300.1 | HM-1000W | E-40 | Black |
| 68300.10 | HM-1000W c/lamp. | E-40 | Black |
| 68300.2 | VSAP-1000W | E-40 | Black |
| 68300.20 | VSAP-1000W c/lamp. | E-40 | Black |

Wiring box located maximum 25 meters from projector.

HM 1000W

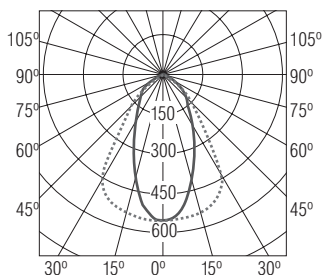

VSAP 1000W

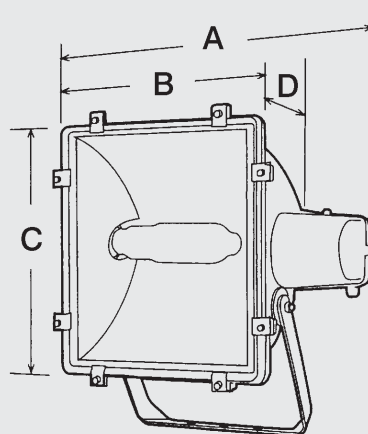
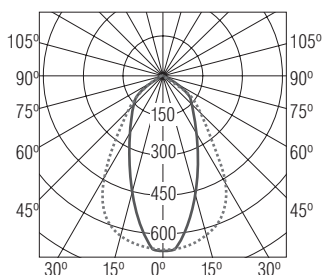

- A 560 mm
- B 465 mm
- C 500 mm
- D 290 mm

HALOGEN PROJECTOR – FARELUX/70-150W

| | | | | |
|----|------|--|------|---------|
| CE | IP65 | | 230V | Class 1 |
|----|------|--|------|---------|

| | |
|-------------------------|---|
| Body | Aluminium die-cast casing |
| Painting | Black/Grey |
| Reflector | Anode process polished aluminium. Available symmetrical, Asymmetrical (A) and Professional. |
| Diffuser | Heat resistant and shock-proof protective glass |
| Supporting brace | Painted steel bar |
| Equipment | Silicone rubber sealing. Porcelain lampholder. Polyamide wiring box. Cablegland. Terminal blocks. Zinc plated internal screws. Stainless steel external screws. |
| Spare-parts | Glass for projector FARELUX/70-150W. Please consult for other spare parts, accessories & colours |

| REF. | POWER | CONNECTION | COLOUR |
|-----------------------|-----------------|------------|------------|
| 68110/68111 | 70W | RX7s | Black/Grey |
| 68110A/68111A | 70W | RX7s | Black/Grey |
| 68110.1/68111.1 | HM-70W | RX7s | Black/Grey |
| 68110.1A/68111.1A | HM-70W | RX7s | Black/Grey |
| 68110.10/68111.10 | HM-70W c/lamp. | RX7s | Black/Grey |
| 68110.10A/68111.10A | HM-70W c/lamp. | RX7s | Black/Grey |
| 68110.2/68111.2 | VSAP-70W | RX7s | Black/Grey |
| 68110.2A/68111.2A | VSAP-70W | RX7s | Black/Grey |
| 68120/68122 | 150W | RX7s | Black/Grey |
| 68120A/68122A | 150W | RX7s | Black/Grey |
| 68120.1/68122.1 | HM-150W | RX7s | Black/Grey |
| 68120.1A/68122.1A | HM-150W | RX7s | Black/Grey |
| 68120.10/68122.10 | HM-150W c/lamp. | RX7s | Black/Grey |
| 68120.10A/68122.10A | HM-150W c/lamp. | RX7s | Black/Grey |
| 68120.2/68122.2 | VSAP-150W | RX7s | Black/Grey |
| 68120.2A/68122.2A | VSAP-150W | RX7s | Black/Grey |
| 68123-Professional | 150W | RX7s | Black |
| 68123.1-Professional | HM-150W | RX7s | Black |
| 68123.10-Professional | HM-150W c/lamp. | RX7s | Black |

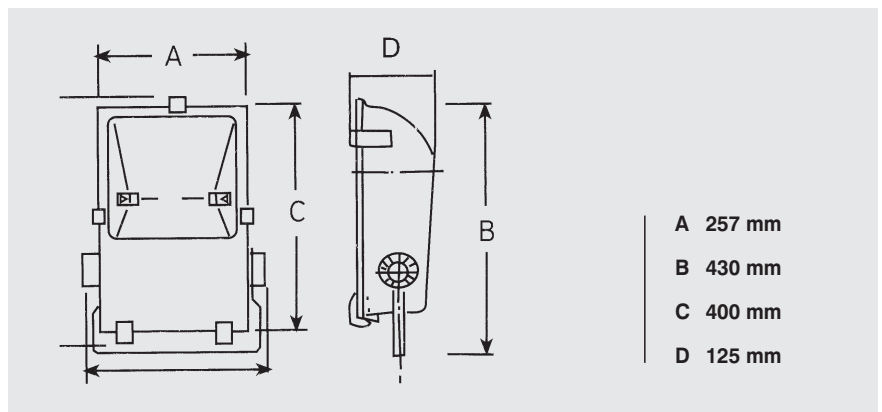
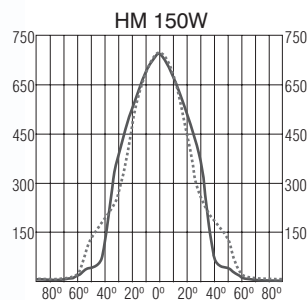

PROJECTOR - FARELUX/250-400W

| | | | | |
|----|------|--|------|---------|
| CE | IP65 | | 230V | Class 1 |
|----|------|--|------|---------|

| | |
|-------------------------|--|
| Body | Aluminium die-cast casing |
| Painting | Black/Grey |
| Reflector | Anode process polished aluminium. Available symmetrical and Asymmetrical (A). |
| Diffuser | Heat resistant and shock-proof protective glass |
| Supporting brace | Painted steel bar |
| Equipment | Silicone rubber sealing. Porcelain lampholder. Polyamide wiring box. Cable gland. Terminal blocks. Zinc plated internal screws. Stainless steel external screws. |
| Spare-parts | Glass for projector FARELUX/250-400W. Please consult for other spare parts, accessories & colours. |

| REF. | POWER | CONNECTION | COLOUR |
|---------------------|-------------------|------------|------------|
| 68130/68132 | 250/400W | E40 | Black/Grey |
| 68130A/68132A | 250/400W | E40 | Black/Grey |
| 68130.1/68132.1 | HM-250W | E40 | Black/Grey |
| 68130.10/68132.10 | HM-250W c/lamp. | E40 | Black/Grey |
| 68130.1A/68132.1A | HM-250W | E40 | Black/Grey |
| 68130.10A/68132.10A | HM-250W c/lamp. | E40 | Black/Grey |
| 68130.2/68132.2 | HM-400W | E40 | Black/Grey |
| 68130.20/68132.20 | HM-400W c/lamp. | E40 | Black/Grey |
| 68130.2A/68132.2A | HM-400W | E40 | Black/Grey |
| 68130.20A/68132.20A | HM-400W c/lamp. | E40 | Black/Grey |
| 68130.3/68132.3 | VSAP-250W | E40 | Black/Grey |
| 68130.30/68132.30 | VSAP-250W c/lamp. | E40 | Black/Grey |
| 68130.3A/68132.3A | VSAP-250W | E40 | Black/Grey |
| 68130.30A/68132.30A | VSAP-250W c/lamp. | E40 | Black/Grey |
| 68130.4/68132.4 | VSAP-400W | E40 | Black/Grey |
| 68130.40/68132.40 | VSAP-400W c/lamp. | E40 | Black/Grey |
| 68130.4A/68132.4A | VSAP-400W | E40 | Black/Grey |
| 68130.40A/68132.40A | VSAP-400W c/lamp. | E40 | Black/Grey |
| 68130.5/68132.5 | VM-250W | E40 | Black/Grey |
| 68130.50/68132.50 | VM-250W c/lamp. | E40 | Black/Grey |
| 68130.5A/68132.5A | VM-250W | E40 | Black/Grey |
| 68130.50A/68132.50A | VM-250W c/lamp. | E40 | Black/Grey |

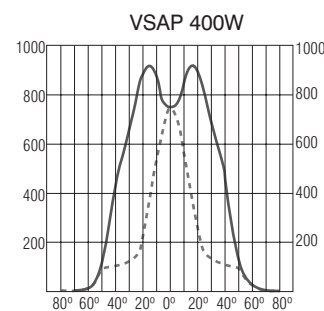
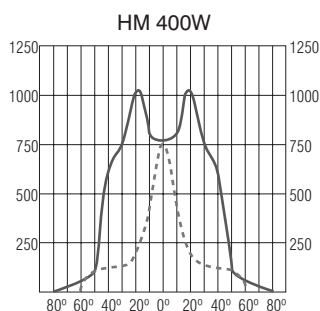

PROJECTOR - FARELUX/250-400W

| | | | | |
|----|------|--|------|---------|
| CE | IP65 | | 230V | Class 1 |
|----|------|--|------|---------|

| | |
|-------------------------|--|
| Body | Aluminium die-cast casing |
| Painting | Black |
| Reflector | Anode process polished aluminium. Available narrow beam and professional. |
| Diffuser | Heat resistant and shock-proof protective glass |
| Supporting brace | Painted steel bar |
| Equipment | Silicone rubber sealing. Porcelain lampholder. Polyamide wiring box. Cable gland. Terminal blocks. Zinc plated internal screws. Stainless steel external screws. |
| Spare-parts | Glass for projector FARELUX/250-400W. Please consult for other spare parts, accessories & colours. |

| REF. | POWER | CONNECTION | COLOUR |
|-----------------------------|-------------------|------------|--------|
| 68134-Intensivo | 250/400W | E40 | Black |
| 68134.1-Intensivo | HM-250W | E40 | Black |
| 68134.10-Intensivo | HM-250W c/lamp. | E40 | Black |
| 68134.2-Intensivo | HM-400W | E40 | Black |
| 68134.20-Intensivo | HM-400W c/lamp. | E40 | Black |
| 68134.3-Intensivo | VSAP-250W | E40 | Black |
| 68134.30-Intensivo | VSAP-250W c/lamp. | E40 | Black |
| 68134.4-Intensivo | VSAP-400W | E40 | Black |
| 68134.40-Intensivo | VSAP-400W c/lamp. | E40 | Black |
| 68133-Profesional | 250/400W | Fc2 | Black |
| 68133.1-Profesional | HM-250W | Fc2 | Black |
| 68133.10-Profesional | HM-250W c/lamp. | Fc2 | Black |
| 68133.2-Profesional | HM-400W | Fc2 | Black |

